

Typographics Pty Ltd

6 Westlands Road
Glen Waverely Vic 3150
T 61 3 9802 2480
M 0438 845 047

E anthony@typographics.com.au

Company Representative

Anthony Pearsall

CAPABILITIES PORTFOLIO

GRAPHIC DESIGN MATTERS.

Your brand is what people say about you
when you're not in the room.

Jeff Bezos, Founder and CEO, Amazon

- CLIENTS
- BOOKS
- PUBLICATIONS
- PRINT ADVERTISING
- GRAPHIC DESIGN
- DIGITAL / WEB
- BRANDING
- SPECIALTY
- LARGE FORMAT



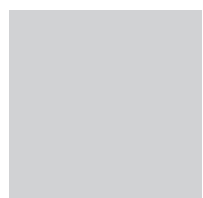

EDITORIAL / BOOKS

Una Deerbon

Mt Buller History

Thredbo

Childrens

Vanity press



Una Deerbon
Large format book
Slip jacket
Foil embossed linen cover

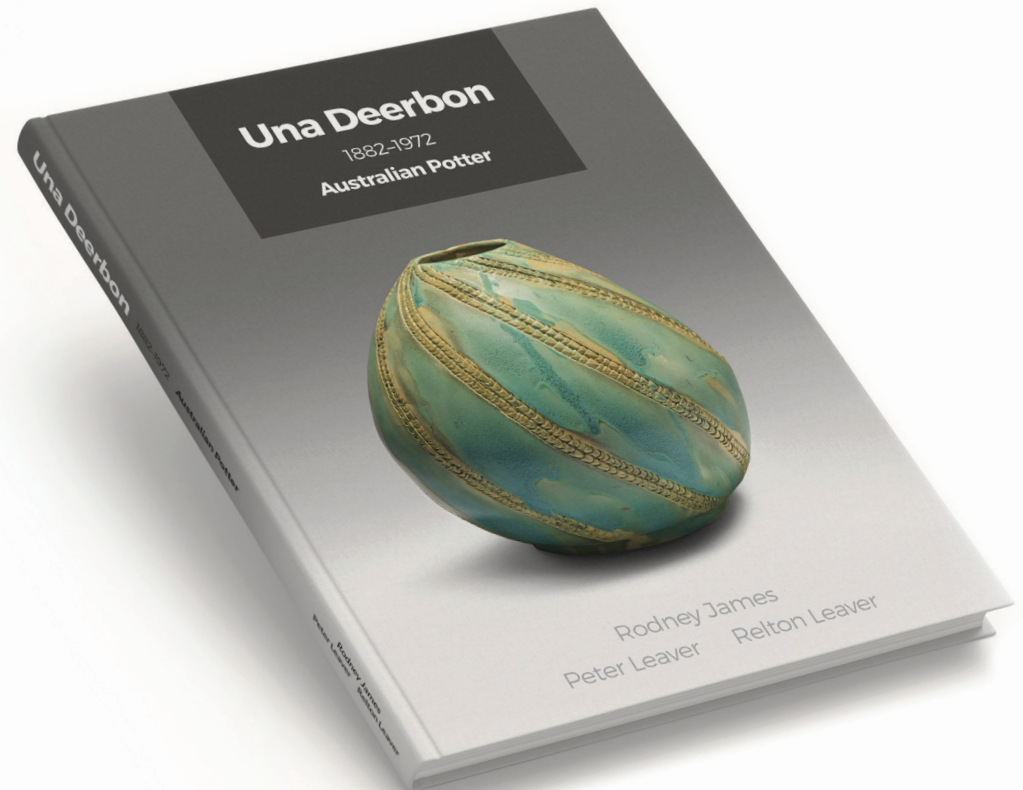

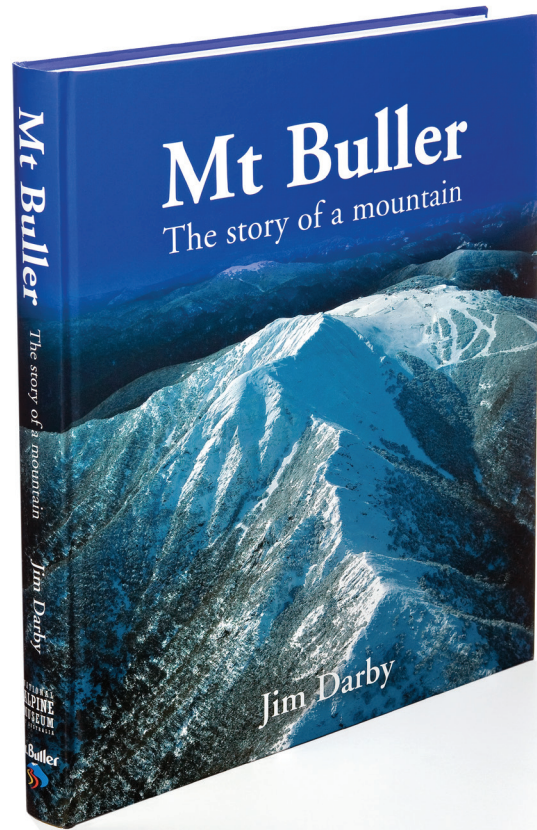

RMYS 140 Years
Slip jacket
Foil embossed linen cover



'1 to 100'
Childrens book
inc. Photography



**TRADE
PUBLICATIONS**

theSKImag

Transpec Digest

Alpine Style

Catalogues



EZCONCEPT

2

04 EZConcept
 Non-vented interior finished. Once in
 ready form. Price varies according to
 room from website.

08 Classic Adjust
 Non-vented interior finished. Once in
 ready form. Price varies according to
 room from website.

11 Single
 Non-vented interior finished. Once in
 ready form. Price varies according to
 room from website.

EZCONCEPT

6

Single
 TRIMLESS DOOR



EZY Jamb[®]
 EZY Jamb Single Rebate - SRC

Provide a premium
 finish with the EZY Jamb
 Single Rebate, a smooth
 transition from door to wall.

The EZY Jamb Single Rebate aligns
 the rebated edge to one side of the
 door only, this defines a clean and
 tidy transition on both sides of the
 door.
 The single piece door frame is
 available in custom widths to fit
 tightly around the framing and
 provides a quick and easy install.

7

**SINGLE REBATE SRC TRIMLESS DOOR FRAME
 (FOR 44mm DOORS)**

Finished Wall Thicknesses:	95mm up to 250mm
	Custom sizes available upon request
Hinges Available	Invisible Type PICOYork RY-45, RY-50, RY-60, RY-80, RY-120 Tichus 340
	EZY Jamb Standard Hinges* 100mm Stainless Steel (SS) 100mm Satin Chrome (SC) 100mm Polished Chrome (PC) 100mm Oil Rubbed Bronze (OB)
	Mortise Hinges PICOYork 100mm x 100mm Ball Bearing and Spring Hinges 100mm Stainless Steel 100mm Satin Chrome 100mm Oil Rubbed Bronze
Strike Options	T Strike 70mm ASA Strike 120mm Deadbolt 70mm
Fire Rating	FD30 and FD60 pending in UK

* All standard hinges are surface applied.

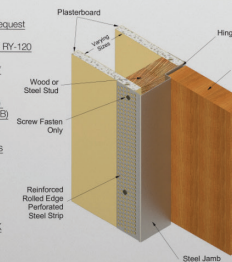



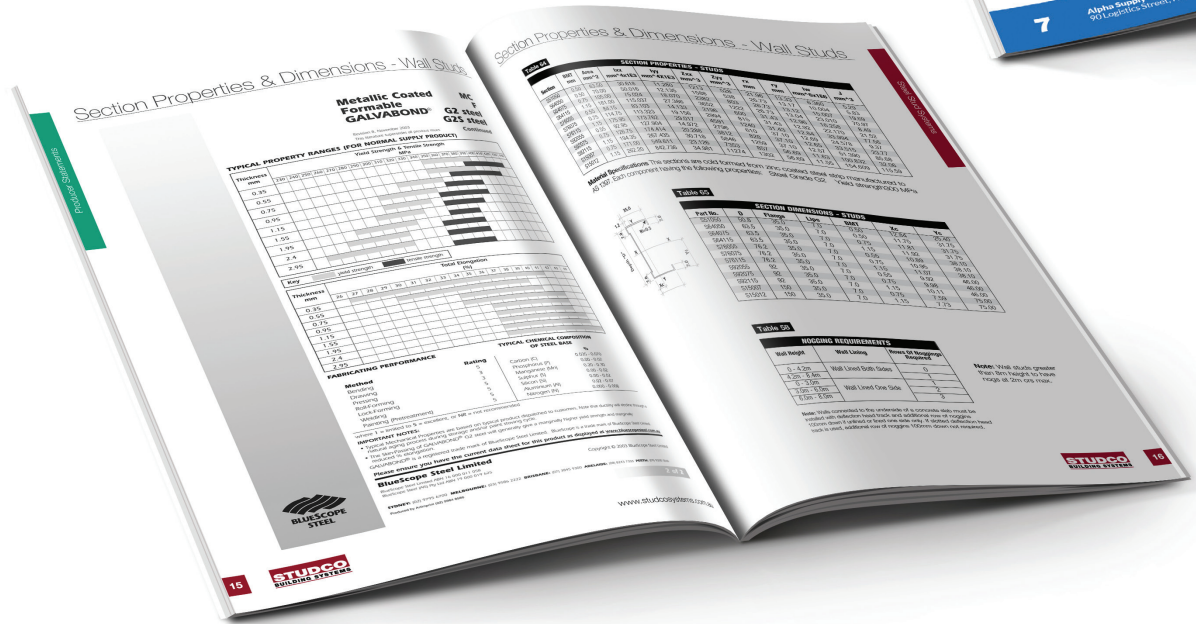



Applied
MACHINERY AUSTRALIA PTY LTD

ALL OF YOUR MACHINERY NEEDS UNDER ONE ROOF
NOW THAT'S APPLIED THINKING

NEW AND USED MACHINERY
SHEETMETAL
ENGINEERING
RECYCLING
PLASTICS

www.appliedmachinery.com.au

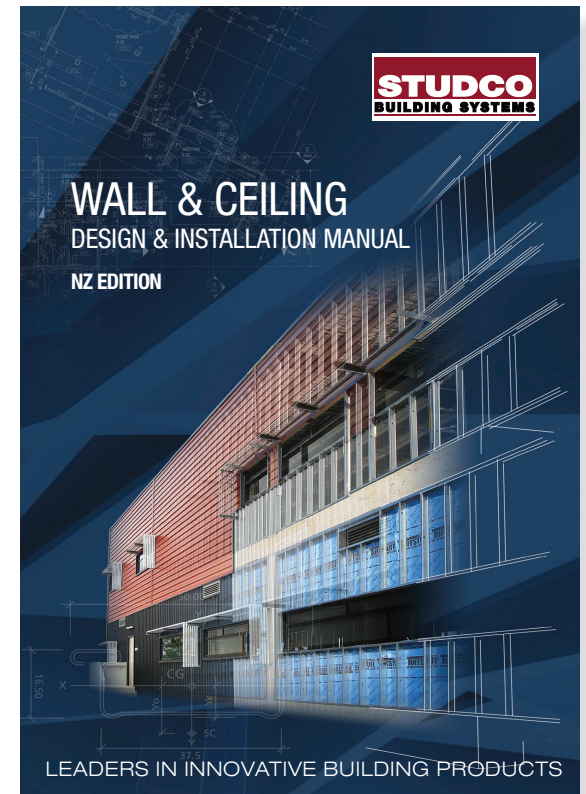

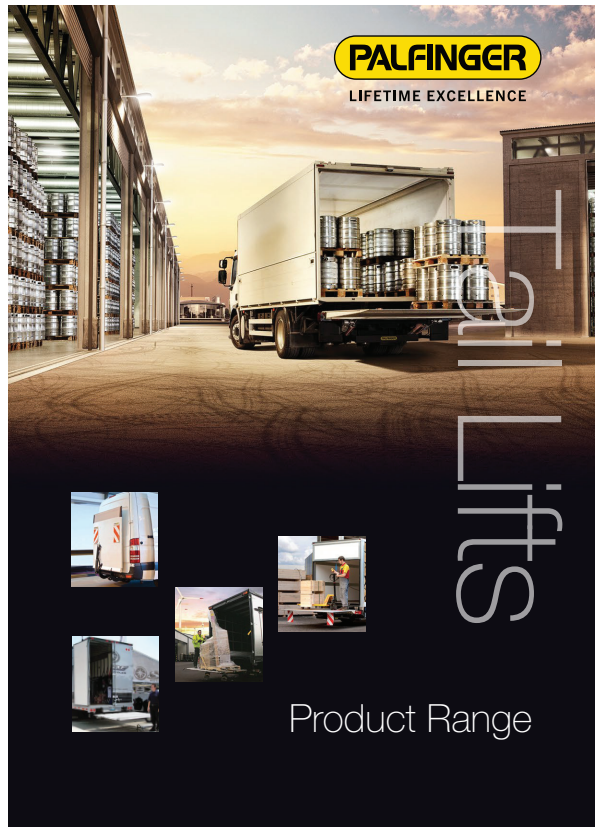

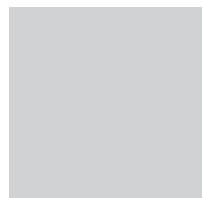

PRINT ADVERTISING

Specialities:

Construction

Transport

Manufacturing



Come and see why Asset Plant & Machinery Stand out from the crowd.

Asset Plant & Machinery is focused on supplying you with the best advice, professional services and products - come and chat with us at our Austech stand, and you'll see why we stand out from the crowd.

We have all types of machines on display to suit your needs...and come along to meet and have your photo taken with the 'Asset Predator'.

Your Partner In Machinery.
 8 Capital Drive Dandenong Vic 3175
 Tel: (03) 8710 8088
 Fax: (03) 8710 8044
 www.assetplant.com
 sales@assetplant.com

Austech 22th - 30th MAY
 SEE US AT STAND F50



PALFINGER
LIFETIME EXCELLENCE

Globally reducing Total Cost of Ownership for owner drivers and fleets through LIFETIME EXCELLENCE

PALFINGER - The number 1 name in Quality, Efficiency, Reliability and Innovation.

PALFINGER - Best in Class

- Lifetime Efficiency
- Exceptional Reliability
- Intelligent Systems
- Safety Innovation
- Unparalleled Durability

MADE IN GERMANY

DESIGNED AND MANUFACTURED IN EUROPE FOR AUSTRALIAN CONDITIONS

GOUGH Transport Solutions

PHONE 1300 300 375
or info@goughtransport.com.au

Melbourne Sydney Brisbane Perth Adelaide



MU-6300V UNIVERSAL CENTRE

AFFORDABLE EXCELLENCE

MAKE THE LEAP ➔

OKUMA
Australia • New Zealand

Built on Okuma's Thermo-Friendly structure, the MU-6300V will perform consistently from the first part to the last, regardless of warmup time or ambient temperature.

OKUMA

For more information call **1300 1 OKUMA** (1300 | 65862)



50% OFF

THE COST OF 90 MINUTE, A & B TRAILER SERVICES IN FEBRUARY*

90 MINUTE SERVICE	A SERVICE	B SERVICE
<ul style="list-style-type: none"> • Brake adjustment and trailer operation checks • Grease 5-cams, slack adjusters and landing legs • Draining of air tank • Visual suspension inspection and report • All relevant parts and consumables 	<ul style="list-style-type: none"> • Brake adjustment and trailer operation checks • Grease all points on trailer • Draining of air tank • Slack pins, king pin and suspension tension • Trailer chassis inspection • Wheel bearing check • Tyre, brake and condition report • Visual suspension inspection and report • All relevant parts and consumables 	<ul style="list-style-type: none"> • Brake adjustment and trailer operation checks • Grease all points on trailer • Draining of air tank • Slack pins, king pin and suspension tension • Trailer chassis inspection • Wheel bearing greater repack • Hub seal replacement • Tyre, brake and condition report • All relevant parts and consumables

AVAILABLE AT MAXITRANS NSW

Available exclusively at our trailer dealership in Smeaton Grange, Sydney, MaxITRANS has a special offer on 90 minute, A & B Trailer Services for a limited time.

Be one of the first 20 customers to book your trailer service in the month of February and receive 50% off the cost of the service.

All types of commercial road transport trailers accepted. Bookings to be confirmed during February and scheduled before June 30th 2018. Full Terms and Conditions below.

MAXITRANS NSW

Located conveniently at 5 Anzac Avenue, Smeaton Grange NSW 2567

New and used sales for all MaxITRANS trailer brands

20,000m² facility offers trailer servicing and all fibreglass, aluminium and steel repairs

Call 1300 629 679

www.maxitrans.com.au to book your next service.



MaxITRANS Australia Pty Ltd is a registered company in Australia. MaxITRANS Australia Pty Ltd is a registered company in Australia. MaxITRANS Australia Pty Ltd is a registered company in Australia.

RU OK?

1%

MAXITRANS WILL DONATE 1% OF THE PURCHASE PRICE TO RU OK?

From all parts purchased, and new trailers or truck bodies ordered, on RU OK? Day, 12 September 2019*



RU OK? is a national suicide prevention charity dedicated to encouraging and empowering people to ask, "are you OK?" of anyone struggling with life.

Continuing its support, MaxITRANS will again donate 1% of the purchase price from all parts purchased, and new trailers or truck bodies ordered, on RU OK? Day, 12 September 2019*. Available from participating MaxITRANS Dealers and MaxIPARTS Outlets.

To add to the contribution, contact your nearest participating MaxITRANS Dealer or MaxIPARTS Outlet today, visit maxitrans.com/find-a-dealer.

RU OK? encourages anyone who is unsure how to have the conversation or approach someone they're worried about to visit www.ruok.org.au/how-to-ask.

For full terms & conditions, visit maxitrans.com/ruok.

*To a maximum of \$15,000.

RU OK? DAY

12 September 2019



Binotto®

THE TIPPING POWER

A complete range of premium tipping hoists for Australian conditions



B3 TECHNICALITY

B3 Cushioning System*
*Custom models only

Well-mount Front-mount Underbody

BRANCHES AUSTRALIA WIDE
1300 300 375 | GOUGHTRANSPORT.COM.AU

GOUGH Transport Solutions

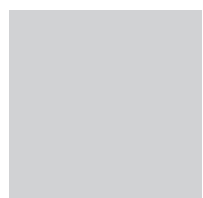

GRAPHIC DESIGN

Multi-page brochures

Flyers

Certificates

Mailers



MAINTAIN CONTROL!

BARE KNUCKLE (BK) RANGE

Lorem ipsum dolor sit amet, consectetur adipiscing elit, sed do eiusmod tempor incididunt ut labore et dolore magna aliqua. Ut enim ad minim veniam, quis nostrud exercitation

BARTLETT
INTEGRATED TOWING SOLUTIONS

P: +61 3 9796 3222 F: +61 3 9796 3510 E: sales@bartlett-equip.com.au



BARTLETT
INTEGRATED TOWING SOLUTIONS

Trailer Breakaway Protection

BARE KNUCKLE

Bartlett Safety Chain Solutions Lead the World

Our reputation for unsurpassed Bare Knuckle is designed and manufactured to the high strength industry standards. Unlike a weak link, our safety chains are designed to remain intact in the event of a failure. Our design ensures that the chain remains intact, preventing the trailer from becoming airborne. Our design ensures that the chain remains intact, preventing the trailer from becoming airborne.

Towbar Attachment

- Retaining cable clip
- Patented knuckle design for optimum strength
- High tensile pins
- Clip fits directly to chain connectors - no extra required

Trailer Attachment

- Spread welds for improved weld strength, weldability and optimum
- Cleanly marked for rating data and traceability
- Heavy duty pinch clip

Engineering Research Supports Chaining Dogs

Bartlett's original safety chain system is based on the principle of a safety chain that is designed to remain intact in the event of a failure. Our design ensures that the chain remains intact, preventing the trailer from becoming airborne.

"I'm one hundred percent confident!"
Robert Smith

Safety Chains For Heavy Trailers, Cost Benefits For Trailers
 - Minimum 100kN
 - 100% of the design load of heavy duty vehicle
 - 100% of the available load for heavy duty vehicle

BARE KNUCKLE
BK RANGE



TRAILER SAFETY CHAIN SYSTEMS



Studco Safety Gift Certificate Program

Safety is Everyone's Responsibility

Receive a Gift certificate for looking out for the safety of a team member.

SEE something unsafe?
SAY something
and be part of the solution

If you are unsure, ask before you start.

STUDCO
BUILDING SYSTEMS

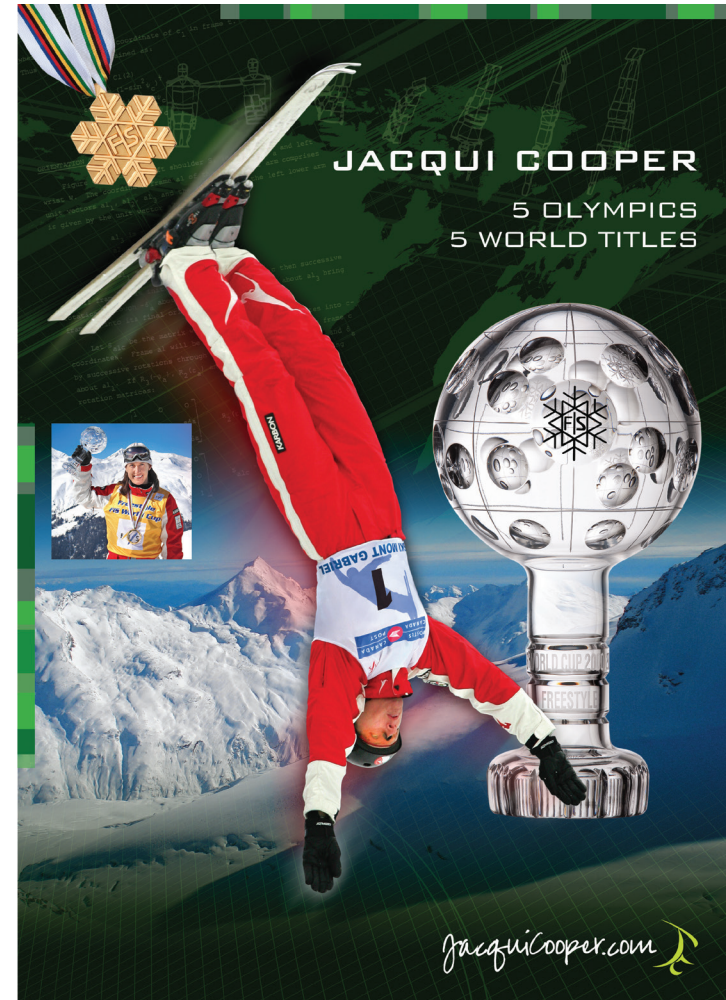

JACQUI COOPER
5 OLYMPICS
5 WORLD TITLES

jacquiecooper.com

Edbro
SETTING THE INDUSTRY STANDARD

CS Series - Top Lift Range

CS17

4 Holes M16 95x104
130x215
70
72" Top plate to foot.
1-1/4" BSPP
A-9" Mounted Centres
70
LxW
32
4 holes Ø20

- Valve pressure setting: Nominal 150 Bar (2.175psi). For maximum pressure ratings refer to individual cylinder drawings.
- Add 25% to swept volume for approximate tank size.
- Weights quoted include nominated brackets.
- 'Z' dimension includes nominated bracket height and an initial pull out of 10mm.
- All dimensions in mm unless otherwise noted.

CS17 MODEL	Stroke (mm)	Z (mm)	A (mm)	B (mm)	S. Vol* (lit)	L x W	Weight (kg)	Pivot Length 50" (mm)
17.4.5166TLB	5,166	1,754*	1,534	80	88	Standard Foot bracket	237	6,147
17.4.5566TLB	5,566	1,854*	1,634	80	95	165 x 343mm	246	6,823
17.4.5966TLB	5,966	1,954*	1,734	80	102	*150mm High	262	7,190
17.4.6366TLB	6,366	2,054*	1,834	80	108	P/N: 181508600	274	7,575
17.5.5983TLB	5,983	1,860*	1,440	80	89	Optional Height	239	7,120
17.5.6483TLBOP	6,483	1,760*	1,540	80	98	70mm	256	7,215

Disclaimer:
The model and details contained in this brochure including prices and specifications are current and correct as at 1 October 2015. We make no liability for errors. Edbro Hydraulic does not take any responsibility for any changes that occur after this date. It is your responsibility to contact your Edbro Sales Branch or representative to ensure that all information and advice is up-to-date before placing an order.

TRANSPEC
ENGINEERED TO LAST

VICTORIA (Head Office)
1-11 Cherry Lane,
Melton, Victoria 3025
Phone (03) 9257 2444
Fax (03) 9258 4828

NEW SOUTH WALES
10 South Place,
Austral Park, Sydney 2148
Phone (02) 8814 7000
Fax (02) 8811 1922

QUEENSLAND
10 Barnhill Street,
Stony Creek 4076
Phone (07) 3217 5877
Fax (07) 3217 5220

WESTERN AUSTRALIA
1021 Abernethy Road,
High Wycombe, WA 6027
Phone (81) 9454 4050
Fax (81) 9454 4111

1300 651 652
info@bpwtranspec.com.au
bpwtranspec.com.au

M310 DOUBLE-ACTING MANUAL

DC POWERPACKS

BUCHER hydraulics

Formerly Monarch Hydraulics

Description:

- Pump/Motor/Reservoir/Valve
- Check valve
- 4-Way manually-operated valve with cam-actuated motor start switch
- Externally-adjustable relief-valve
- Working ports 1/4" NPT
- Horizontal mounting standard

HYDRAULIC SCHEMATIC (STANDARD VALVE)

SIDE VIEW

END VIEW

ORDERING CODE: **M310.14157.12V.QC**

Blank - Standard valve
QC - Open-centre valve

12V or 24V DC

TANK	VOLUME litres	TYPE material / shape	A mm	C mm	D mm
14157	3.2	Poly <input type="checkbox"/>	437	253	169
6954	8.3	Steel <input type="checkbox"/>	645	253	184

BRANCHES AUSTRALIA WIDE
1300 300 375 | GOUGHTRANSPORT.COM.AU

GOUGH Transport Solutions

YANMAR **ROCXquip**

YANMAR Excavators

If you're looking for long-term value, you can't go past the Yanmar range of construction equipment.

As a hard working and profit-conscious operator you need a reliable machine that gets to work and keeps on working as hard as you do for years to come.

When you buy or rent from us you can be confident that your dozer, loader, excavator, track loader or skidsteer will keep on performing — giving you a great return on investment year after year. Benefit NOW from the high manufacturing standards and unbeatable cost-effectiveness of our machines to ensure you do the job right.

Buy now before December 30th and take advantage of the Section 179 Deductions

rocXquip

PRODUCT CODE: **Resimat**
PUBLICATION DATE: **April 2016**

Resimat RM602

Recycled rubber impact sound isolation



Another Quality Building Product



A flat, resilient, recycled rubber underlayment to be used directly under most floor finishes, yielding exceptional results even under hard surface flooring, over concrete and wood joist construction.



PERFORMANCE ATTRIBUTES

- Can thin-set tile and stone directly to the product per ASTM C827.
- Compatible with most floor finishes.
- Fast installation.
- Available in 48" wide rolls and a variety of thicknesses.
- Vapor barrier option available.
- Crack isolation membrane protects ceramic, porcelain and stone tile from substrate cracks.
- Rated extra heavy by the Tile Council of North America.
- Passes VOC Washington State IAQ Test (ASTM D5116).
- Can contribute toward earning up to 9 LEED.

DIMENSIONS

- 2mm in 4" by 75" (1.2m by 22.9m) roll size.
- Sheet Weight: 0.37lb/sq'
- Standard Tolerances: Width: +3/4" - 0"; Length: +1 1/8" - 0"; Thickness: ±0.3mm

ACOUSTICS

Backed by over 400 independent lab and field tests, Resimat has been proven to provide the highest levels of IC sound isolation in the industry. Contact us to access the test reports that meet your needs.

SAMPLE RATINGS: **IC 72, STC 72** with wood flooring, 1 layer Resimat RM602; **IC 70** reinforced concrete slab, suspended ceiling (ANSI S000001, 7000kg); **IC 50, STC 63** with LVT flooring, 1" gypsum concrete, Resimat RM602, wood truss, resilient channels, suspended ceiling (ATH-C8700/05-113-11 #93).



TECHNICAL DATA

PROPERTY	TEST METHOD	TYPICAL RESULTS
Density	ASTM D2097	0.22 g/cm ³ , min.
Thickness	ASTM D2676	2mm (0.08")
Tensile Strength	ASTM D415, Die C	80 psi, min.
Elongation	ASTM D415, Die C	50%, min.
Tear Strength	ASTM D624, Die C	30 psi, min.
Compression @ 100 psi recovery	ASTM F36	20-30%, 85%, min.
Short A Hardness	ASTM D2493	40
Resiliency	ASTM F147	1 factor, max.
Compression Set @ 25% Deflection, 158"/22 hrs	ASTM D3056	40% max.
Coefficient of Friction	ASTM D1894	1.2
Crack Resistance	ANSI 118.12.5-4	High Performance

The values shown represent current production based on standard Resimat specs and may vary per thickness. Information contained within this document supersedes all previous versions and is subject to change without notice.

For Technical Support and Sales Enquiries, please contact Studco Building Systems 800.675.8023

1700 BOULDER INDUSTRIAL PARKWAY WEBSTER NY 14580 | PH: 800.675.8023 | sales@resilmount.com | www.resilmount.com

1/1

RESILMAT - FINISHES - FINISHES

GOUGH Transport Solutions

4.5T Rated Towbar (Towball)

Suits 50mm and 70mm Towballs

PHONE: 1300 300 375
sales@goughtransport.com.au
www.goughtransport.com.au



Component view

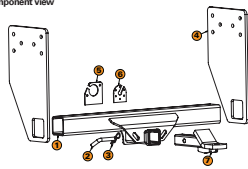

- Maximum ATM Rating 4500kg.
- Complies with the requirements of ADR62/02 (Mechanical connections between vehicles).
- Weight 50kg.
- Includes Gough Transport Part numbers TSA-001 & TSA-002.

ITEM #	DESCRIPTION	QTY
1	Crossmember Assembly	1
2	Towbar Pin	1
3	R-Clip	1
4	Stopweld	2
5	ABS Plug Bracket	1
6	Light Plug Bracket	1
7	Towball Hitch (TSA-002)	1

Optional Extras:

- 50mm Towball
- 70mm Towball

WORLD'S BEST PRODUCTS, WORLD'S BEST SERVICE

GOUGH Transport Solutions



PRODUCT CATEGORY PROFILE:

TAIL LIFTS

TAIL LIFT SOLUTIONS SUPPORTING SAFE & EFFICIENT WORKING ENVIRONMENTS.

AN EXTENSIVE RANGE OF TAIL LIFT OPTIONS FROM PREMIER BRAND PALFINGER.

Palfinger delivers a product that is synonymous with the outstanding quality of the Palfinger name along with decades of experience in tail lift development and market leadership.

Leading operators across many fields operate Palfinger tail lifts – this includes major food & beverage distributors, courier and postal, tyre companies, logistics and emergency services.

Palfinger tail lifts are high quality and comes with an impressive list of standard features.

Tail lifts can also be customised to suit the specific needs of your fleet such as fire trucks and other vehicles with specific requirements. Platform lift-arm kits are a popular solution for utilities and service bodies.

PALFINGER

COMPLETE TAIL LIFT SOLUTIONS:

- Telescopic Tail Lifts
- Conventional Tail Lifts
- Retractable Tail Lifts
- Van-specific Tail Lifts
- Specialist Support & Consultation Services

QUALITY FEATURES ...

- Hydraulic Cylinder Manufactured in-house
- LED Working Lights For Enhanced Safety
- Insulated Feet Guards
- Level Roll Stops For Safety

NATIONAL SERVICE PARTNER NETWORK

NATIONAL SALES & PRODUCT SUPPORT TEAM

WORLD LEADING BRANDS PRODUCED IN AUSTRALIA

OUR COMMITMENT - YOUR SUCCESS

A MEMBER OF **GOUGH** GROUP OUR COMMITMENT - YOUR SUCCESS

AUSTRALIA WIDE
1300 300 375
GOUGHTRANSPORT.COM.AU
MELBOURNE • SYDNEY • BRISBANE • PERTH • ADELAIDE

1/1



Binotto

THE TIPPING POWER

Binotto Cylinders

Binotto designs, manufactures and distributes a complete range of hoists for all tipping applications.

- Underbody, front-mount and well-mount configurations.
- 2 to 100 tons capacity
- 3-way taper options
- Rear-tipping and side-tipping applications

Binotto Construction

The key features and superior seal and viper system of Binotto hoists, ensure they operate and are proven in the most extreme environments, from Siberian steppes to Saudi deserts.

- Only high-quality steel producers are accepted as Binotto strategic suppliers (such as Dalmine and Mannesmann)
- All stages and outer tubes are manufactured exclusively from seamless steel-tube with a high yield-point (R_e = 48 kg/mm²) and high tensile strength (R_m = 65 kg/mm²)
- Binotto stages are roll-hardened for exceptional smoothness. This feature, along with the use of special bushes, ensures a clearance of no more than 0.07mm between stages is achieved – a vital aspect in resisting side-loads and bending factors.
- The internal and external “rolling” burnishing process for all stages and outer tubes, increases steel performance and life, resulting in more reliable and long-lasting products.
- A solid-stage design and absence of stop-removing rings is an unsurpassed solution. Binotto’s design, with slope-contact faces machined directly from solid tube, without welds, provides maximum safety and service life. (B3 models)



Front-mount hoists

Well-mount hoists

Underbody hoists

THE TIPPING POWER



Binotto Quality

Binotto operates under the highest International Quality Standard (ISO 9001). This gives the group the ability to combine state-of-the-art plant automation with the expertise of its staff.

- Controlled and documented processes and procedures
- Continual process optimisation
- Skilled and dynamic staff
- Spirit of initiative and continuous research
- Company culture targeted at quality
- Dedicated and proficient customer service



Binotto

THE TIPPING POWER

UNDERBODY TIPPING HOIST

BOTTOM-TRUNNION TYPE

A SERIES

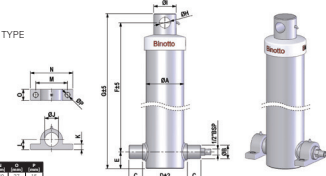

CODE	STAGES	HEIGHT	CAPACITY	WEIGHT	ST1	ST2	ST3	ST4	ST5	ST6	ST7	ST8	ST9	ST10	ST11	ST12
AA05.0700	3	870	5	7.0	10	10	10	10	10	10	10	10	10	10	10	10
AA05.0810	3	870	5	8.1	10	10	10	10	10	10	10	10	10	10	10	10
AA05.0915	3	870	5	9.15	10	10	10	10	10	10	10	10	10	10	10	10
AA05.1100	3	870	5	11.0	10	10	10	10	10	10	10	10	10	10	10	10
AA05.1200	3	870	5	12.0	10	10	10	10	10	10	10	10	10	10	10	10
AA05.1300	3	870	5	13.0	10	10	10	10	10	10	10	10	10	10	10	10
AA05.1400	3	870	5	14.0	10	10	10	10	10	10	10	10	10	10	10	10
AA05.1500	3	870	5	15.0	10	10	10	10	10	10	10	10	10	10	10	10
AA05.1700	3	870	5	17.0	10	10	10	10	10	10	10	10	10	10	10	10
AA05.2100	3	870	5	21.0	10	10	10	10	10	10	10	10	10	10	10	10

FRONT-MOUNT TIPPING HOIST

MFC075 SERIES

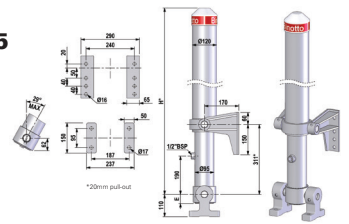

CODE	STAGES	HEIGHT	CAPACITY	WEIGHT	ST1	ST2	ST3	ST4	ST5	ST6	ST7	ST8	ST9	ST10	ST11	ST12
MFC075.2000	8	2000	10	20.0	10	10	10	10	10	10	10	10	10	10	10	10
MFC075.2000	8	2000	10	20.0	10	10	10	10	10	10	10	10	10	10	10	10

UNDERBODY TIPPING HOIST

EYE-TO-EYE TYPE

AA SERIES

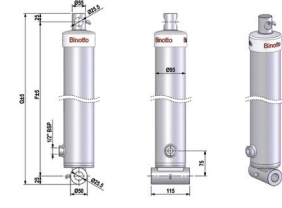

CODE	STAGES	HEIGHT	CAPACITY	WEIGHT	ST1	ST2	ST3	ST4	ST5	ST6	ST7	ST8	ST9	ST10	ST11	ST12
AA05.1100	3	1100	5	11.0	10	10	10	10	10	10	10	10	10	10	10	10
AA05.1100	3	1100	5	11.0	10	10	10	10	10	10	10	10	10	10	10	10

FRONT-MOUNT TIPPING HOIST

MFC090 SERIES

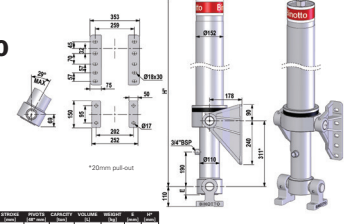

CODE	STAGES	HEIGHT	CAPACITY	WEIGHT	ST1	ST2	ST3	ST4	ST5	ST6	ST7	ST8	ST9	ST10	ST11	ST12
MFC090.2076	8	2076	10	20.76	10	10	10	10	10	10	10	10	10	10	10	10
MFC090.2076	8	2076	10	20.76	10	10	10	10	10	10	10	10	10	10	10	10
MFC090.2076	8	2076	10	20.76	10	10	10	10	10	10	10	10	10	10	10	10



CERTIFICATE OF APPRECIATION

THIS CERTIFICATE IS AWARDED TO:

IN RECOGNITION OF ACHIEVING

25 YEARS SERVICE

with MaxiTRANS

DATE:

Dean Jenkins - Managing Director MaxiTRANS



WAVERLEY CAMERA CLUB 

BEST OPEN PRINT 2019

FIRST PLACE

AWARDED TO

Anthony Yap

FOR THE IMAGE

Contemplation



Russell Lucas
President, WCC
DECEMBER 3, 2019



\$5000 VOUCHER *VALID UNTIL JUNE 30, 2020

REDEEMABLE AT MAXITRANS FOR PARTS, SERVICE OR NEW TRAILERS

TERMS & CONDITIONS

Freightliner, Maxi-Cube, Lusty EMS, HameloxWhite, IAIMEB, PEH, MaxiPARTS

CNC PLASMA CUTTING WITH HYPER THERM POWERMAX® AND FASTCAM® PROFESSIONAL FROM \$24,900.* GST

THAT'S APPLIED THINKING

BONUS \$250

BEST PRICES ASSESSED & UPDATED

FREE ASSET PLANT & MACHINERY

Don't miss out!

...on your copy of Australia's Most Comprehensive **Metalworking and Machinery Catalogue**

- Most Comprehensive Product Range
- Technical, Sales, and Service Advice
- Finance Services Available
- Installation and Training Available
- Easy and Efficient Ordering

ASSET PLANT & MACHINERY

8 Capital Drive, Dandenong VIC 3175
Tel: 03 9719 8088 Fax: 03 9719 8044
www.assetplant.com sales@assetplant.com

We're Your Partner In Machinery.

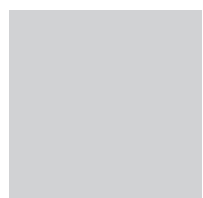

DIGITAL DESIGN

Websites

eDM

MREC Banners

Slideshows

eSignatures

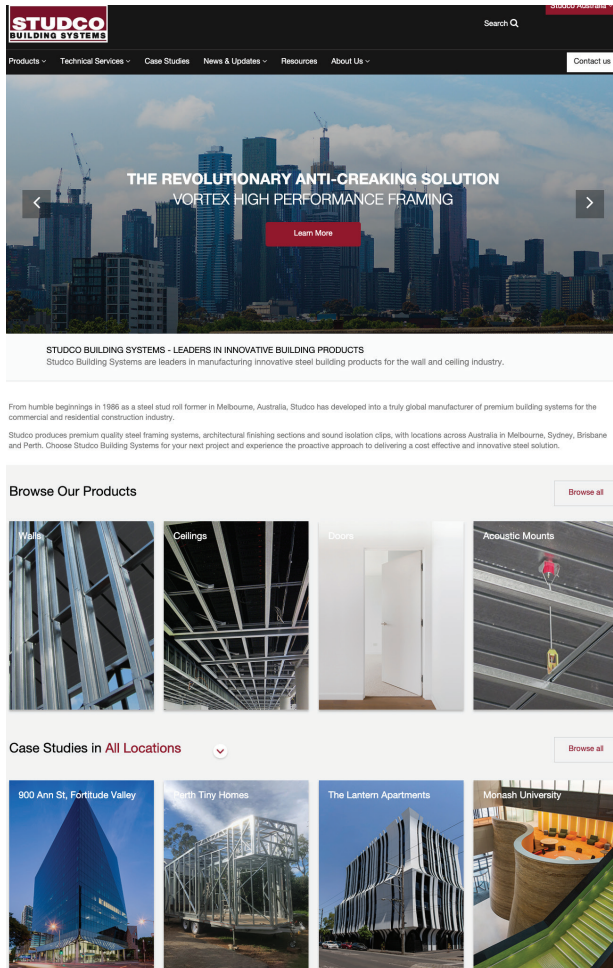

Drupal website

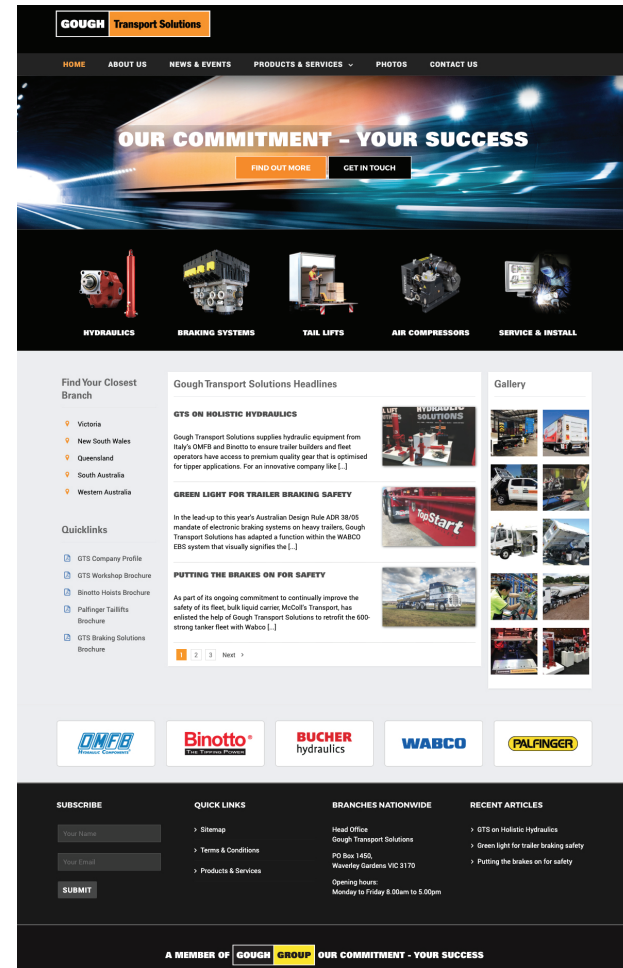

Wordpress website

DANIEL FISHER
Marketing Manager, Applied Machinery



A: 55-61 Nissan Drive, Dandenong
Victoria 3175 Australia
E: daniel.fisher@appliedmachinery.com.au www.appliedmachinery.com.au

P: 03 9706 8066
F: 03 9706 8067

[f](#) [t](#) [in](#) [v](#) [@](#) [G+](#) [••](#) [Check out our latest full colour machinery catalogue here](#)

eSignature



5-AXIS MACHINING POWERHOUSE

Robust performance and small footprint with the GENOS M460V-5AX

The next generation GENOS M460V-5AX, 5-axis vertical machining centre made in Japan, is specifically designed to manufacture high precision parts and deliver impressive metal removal rates in a compact design. Its solid double-column structure, full 5-axis simultaneous control and thermal stability performance give it the ability to easily cut a variety of materials.



The Okuma Advantage Intelligent Technology

These features are unique to Okuma because we make every part of our machines and controls. We create applications highly tailored to enhance each machines performance. By leveraging the power of the OSP control, Okuma has enriched its machines and controls with Okuma's Intelligent Technology.

[Read More](#)

Real People, Real Passion - Discover Okuma

When you deal with Okuma, you're dealing with the experts.



SERVICE

Nulla consequat massa quis enim. Donec



PARTS

Nulla consequat massa quis enim. Donec



SALES

Nulla consequat massa quis enim. Donec



Okuma Australia Pty Ltd

[View online](#) | [Unsubscribe](#)

eDM



Contact | Call 03 9888 0175

MAY 2019
PREMIUM PRODUCTS
QUALITY SERVICE



PRODUCTS YOU CAN TRUST FOR PERFORMANCE AND RELIABILITY

Global Clamps have scoured the globe to source the best quality, most reliable industrial clamping solutions for your business.

We recognise the importance of our products being mission critical in applications that rely on high performance, reduce the risk of failure, protect down time and maintain the efficient running of machines and equipment.

Applications include:
• Hoses • Pipes • Cables • Cylinders • Signs • Ducts

BRINGING TOGETHER THE BEST BRANDS

We stock and source a comprehensive range of products from key European OEM suppliers, ensuring the highest quality and performance from each and every part.



Kale

Mubea



Bandimex

Callau

MPC

Global Clamps

For more information on our range of clamps and connectors contact **Global Clamps** today.



With more than 30 years industry experience, Global Clamps specialise in the supply of premium-quality engineered clamps and connectors to a wide range of manufacturers and industries throughout Australia and New Zealand.

[f](#) [t](#) [in](#) [v](#) [@](#) [G+](#) [••](#) info@globalclamps.com.au

eDM

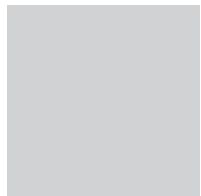

BRANDING / STATIONERY

Brand manifest

Style guides

Logo design

Corporate Stationery

Forms

Internal documentation

Documentation

Instructions

VEHICLE REFERENCE
 VIN: JKAJF817L000277
 Towbar Serial No.: 2124677

Vehicle Stock No.: N/A
 Job Reference: N/A

JOHN CITIZEN
 JC TRUCK BODIES
 123 ANY STREET
 ANYTOWN
 NSW 2042

BARTLETT
 INTEGRATED TOWING SOLUTIONS

BARTLETT TOWBAR
 GUIDE TO RATED CAPACITIES

TOWING AND LOAD SHARE DIAGRAM

VEHICLE DATA AND RATINGS

Make	ISUZU
Model	FSS 580
VIN	JALFSS34F67000110
Build Year / Month	2008 / -
GCM	15.00 tonne
GVM	10.00 tonne
BT500 (Ser:72M022)	11.44 tonne
Wallace R15	11.44 tonne
13mm	11.44 tonne
11mm	11.44 tonne
10mm	11.44 tonne
9mm	11.44 tonne
8mm	11.44 tonne
7mm	11.44 tonne
6mm	11.44 tonne
5mm	11.44 tonne
4mm	11.44 tonne
3mm	11.44 tonne
2mm	11.44 tonne
1mm	11.44 tonne

VEHICLE REFERENCE
 VIN: JKAJF817L000277
 Towbar Serial No.: 2124677

Vehicle Stock No.: N/A
 Job Reference: N/A

JOHN CITIZEN
 JC TRUCK BODIES
 123 ANY STREET
 ANYTOWN
 NSW 2042

50mm BALL & TRAILER COUPLING RATINGS

Ball Weight	Trailer Weight	Truck Weight	Truck Mass (Gross)
200kg	100kg	100kg	100kg
250kg	125kg	125kg	125kg
300kg	150kg	150kg	150kg
350kg	175kg	175kg	175kg
400kg	200kg	200kg	200kg
450kg	225kg	225kg	225kg
500kg	250kg	250kg	250kg

COMBINATION TONNES - TRUCK TO THE LEFT AND TRAILER TO THE RIGHT, MAXIMUM LOAD SHARE SVL INDICATED WHERE APPLICABLE

BARTLETT
 INTEGRATED TOWING SOLUTIONS

TOWBAR RATING REPORT
TOWBAR RATING PLATE

SEPTEMBER 17
 ISUZU
 VIN 6F2252300WDE00794
 FV1240-300
 BT1400A
 14A2209

COUPLING 19 **ATM TONNES SVL TONNES** 1.0 **D VALUE kN** 88.3

AUTOMATIC PIN

DO NOT EXCEED COUPLING OR TOWBAR RATINGS - FOR TOWING PURPOSES ONLY
www.bartlett-equip.com.au

PO Box 228, Hellen, Victoria 3203 Australia P. 61 3 9796 3222 F. 61 3 9796 3610 E. sales@bartlett-equip.com.au www.bartlett-equip.com.au

HEAVY DUTY TRUCK & TRAILER TOWBARS COUPLINGS SAFETY CHAIN SYSTEMS

Typographics Design



WARRANTY AND PRODUCT SUPPORT
WARRANTY CLAIM FORM



Please complete details below and return with goods for warranty inspection.

CLAIMANT DETAILS, PLACE OF PURCHASE		EQUIPMENT USER DETAILS	
Name	<input type="text"/>	Name	<input type="text"/>
Company	<input type="text"/>	Company	<input type="text"/>
Address	<input type="text"/>	Address	<input type="text"/>
State	<input type="text" value="-- Select --"/>	State	<input type="text" value="-- Select --"/>
Postcode	<input type="text"/>	Postcode	<input type="text"/>
Phone	<input type="text"/>	Phone	<input type="text"/>
Fax	<input type="text"/>	Fax	<input type="text"/>
Email	<input type="text"/>	Email	<input type="text"/>

PRODUCT DETAILS	DESCRIPTION
Manufacturer <input type="text"/> Description <input type="text"/> Model <input type="text"/> Number of items <input type="text"/> Date of Purchase <input type="text"/> Bartlett Invoice No. <input type="text"/> Date that the defect was first observed <input type="text"/>	<div style="border: 1px solid #ccc; width: 100%; height: 100%;"></div>

Declaration: Text to be supplied Luptum, que nos illo ipsum vellendi od qui dui, que etOditatest maioisandi velles est, coree solupta vid magnimenda cor sim eum seque mos ipsis aliaaspiciat quo voler mo conseed aerum, te doluptase pre susa doluptam, velis untorematem quost.

SIGNATURE OF CLAIMANT DATE

Fax to (03) 9796 3222 Email to info@bartlett-equip.com.au

PO Box 239, Hailam, Victoria 3803 Australia P: 61 3 9796 3222 F: 61 3 9796 3510 E: sales@bartlett-equip.com.au www.bartlett-equip.com.au

HEAVY DUTY TRUCK & TRAILER TOWBARS | COUPLINGS | SAFETY CHAIN SYSTEMS

**RATING PLATE
REQUEST FORM**



Save time and fill this form online at:
<https://integratedtowingsolutions.com/rating>

BARTLETT TOWBAR INFORMATION

The towbar serial number (eg. 14B0001) is stamped into a permanent Bartlett identification plate attached to the towbar.

TOWBAR MODEL	SERIAL NUMBER
<input style="width: 100%;" type="text"/>	<input style="width: 100%;" type="text"/>

TRAILER COUPLINGS

Some Bartlett towbars support multiple trailer couplings (eg. BARTLETT BALL 127mm, PINTLE HOOK P1300 OR AUTOPIN AUS-303). Please provide details below.

MAKE & MODEL	
1ST COUPLING <input style="width: 100%;" type="text"/>	3RD COUPLING (if applicable) <input style="width: 100%;" type="text"/>
2ND COUPLING (if applicable) <input style="width: 100%;" type="text"/>	4TH COUPLING (if applicable) <input style="width: 100%;" type="text"/>

RATED OR NOMINATED ATM LIMIT:

IF APPLICABLE: Truck manufacturer's ATM rated limit, OR nominate a custom maximum ATM for this truck kg Tick box if you would like to discuss with Bartlett

VEHICLE DETAILS

MAKE <input style="width: 100%;" type="text"/>	GVM <input style="width: 50px;" type="text"/> kg
MODEL <input style="width: 100%;" type="text"/>	<small>Gross Vehicle Mass (total mass of towing vehicle)</small>
BUILD MONTH/YEAR <input style="width: 20px;" type="text"/> / <input style="width: 20px;" type="text"/>	GCM <input style="width: 50px;" type="text"/> kg
	<small>Gross Combination Mass (total mass of truck and trailer)</small>
VIN <input style="width: 100%;" type="text"/>	OPERATIONAL TARE <input style="width: 50px;" type="text"/> kg
<small>Vehicle Identification Number (total mass of truck and trailer)</small>	<small>Unladen truck mass, including body, modifications and permanent enhancements</small>
TRAILER BRAKING <input type="checkbox"/> Electric brakes <input type="checkbox"/> Bartlett Standard Sideplates fitted?	TRUCK WHEELBASE (mm) <input style="width: 50px;" type="text"/> mm
<input type="checkbox"/> Air brakes <input type="checkbox"/> Yes	COUPLING OVERHANG (mm) <input style="width: 50px;" type="text"/> mm
<input type="checkbox"/> No braking <input type="checkbox"/> No	<small>Distance from the centre of coupling to the centre of the rear axle group</small>

TRUCK TOWBARS | TRAILER COUPLINGS | SAFETY CHAIN SYSTEMS

Document no: 98-1001_03

Typographics Design

10mm 110mm 80mm 10mm

10mm 5mm 20mm or 25mm 5mm 5mm

OCCUPATIONAL HEALTH AND SAFETY
SAFE WORK PROCEDURE

BARTLETT
INTEGRATED TOWING SOLUTIONS

Header segment

8pt Helvetica LT Std Light
DEPARTMENT/SECTION HEADING
SINGLE HEADING LINE
17pt Helvetica LT Std Bold
20mm Single deck heading

DEPARTMENT/SECTION HEADING
HEADING LINE 1
HEADING LINE 2
17pt Helvetica LT Std Bold (17/19pt leading)
25mm Double deck heading

17pt Helvetica LT Std Bold No department/section heading
HEADING LINE 1
HEADING LINE 2
Justify vertically for both single or double line headings
Alternative
Standard 20mm heading block to accommodate both single and double deck headings

Form/content segment (See additional Style Guide/s)

10% Black

Q O F A P D

C: 100 C: 0 C: 100 C: 0 C: 0 C: 20
M: 0 M: 100 M: 0 M: 0 M: 100 M: 80
Y: 0 Y: 80 Y: 100 Y: 0 Y: 100 Y: 0
K: 0 K: 0 K: 0 K: 80 K: 0 K: 20

8pt Helvetica LT Std Bold
Date: 10/10/2018

5pt Helvetica LT Std Light (5/6pt leading)
© BARTLETT EQUIPMENT 2018. Privileged and confidential information.

8pt Helvetica LT Std Light (8/9.6pt leading)
7pt Helvetica LT Std Light (5/6pt leading)
G:\Denise\BTI Workplace Processes\Process Sheet Template\Process Sheet Template (3).docx

12mm 280mm

12mm 5mm 10mm 12mm 3mm 175mm 10mm

Footer segment

Q Date: 10/10/2018 Author: Denise Hartland Doc. No.: 001002
Path: G:\Denise\BTI Workplace Processes\Process Sheet Template\Process Sheet Template (3).docx
© BARTLETT EQUIPMENT 2018. Privileged and confidential information remains the property of Bartlett Transport Improvements. Intended only for use by Bartlett Equipment. Unintended external recipient's must destroy the document and all copies of this information.

Alternative

Q Date: 10/10/2018 Author: Denise Hartland Doc. No.: 001002
Path: G:\Denise\BTI Workplace Processes\Process Sheet Template\Process Sheet Template (3).docx
© BARTLETT EQUIPMENT 2018. Privileged and confidential information remains the property of Bartlett Transport Improvements. Intended only for use by Bartlett Equipment. Unintended external recipient's must destroy the document and all copies of this information.

Note: Alternative version if the 5pt text is unreadable from the laser printer.

6pt Helvetica LT Std Light 6pt Helvetica LT Std Light (6/7pt leading)

- 13pt Bold
- 10pt Bold
- 13pt Bold
- 10pt Bold
- 9pt Light
- 11pt Bold Oblique
- 13pt Bold
- 11pt Bold
- 9pt Light

CRITICAL RISK ASSESSMENT FORM

BARTLETT
INTEGRATED TOWING SOLUTIONS

RISK NUMBER ISSUE DATE REVISION PAGE

1. INFORMATION

WORKPLACE	Bartlett Transport Improvements	OFFICE USE ONLY	
RISK TITLE		DESIGNATION	
DATE LAST REVIEWED		NEXT REVIEW DATE	

2. DOCUMENTATION

RELEVANT STANDARDS / DOCUMENTATION	YES / NO	COMMENTS
Are instruction manuals accessible?	Y <input type="checkbox"/> N <input type="checkbox"/>	
Is a safe work procedure (SWP) required to be developed (TO BE COMPLETED ONCE THE RISK ASSESSMENT HAS BEEN CONDUCTED)?	Y <input type="checkbox"/> N <input type="checkbox"/>	

REFER TO APPENDIX A – HAZARD INSPECTION CHECKLIST FOR GUIDANCE ON POTENTIAL HAZARDS

3. RISK ASSESSMENT

IDENTIFY TASK Think about the work area and each stage of the work to be performed.	IDENTIFY HAZARDS Against each stage/item list the hazards that could cause injury/incident when performed	RISK RATING Refer to CHS Risk Management Procedure			RISK CONTROL MEASURES List the control measures required to eliminate or minimise the risk.
		CONSEQ	LIKELD	RISK LEVEL	
1.					
2.					
3.					

Q Date: 10/10/2018 Author: Denise Hartland Doc. No.: 001002
Path: G:\Denise\BTI Workplace Processes\Process Sheet Template\Process Sheet Template (3).docx
© BARTLETT EQUIPMENT 2018. Privileged and confidential information remains the property of Bartlett Transport Improvements. Intended only for use by Bartlett Equipment. Unintended external recipient's must destroy the document and all copies of this information.

Typeface - Helvetica LT Std family

100% Black

60% Black

10% Black

0% Black (White)

40% Black
0.5pt

PRO-FITTER
NETWORK



rocrents 

HEDA[®]
TOUGH WALL SYSTEM

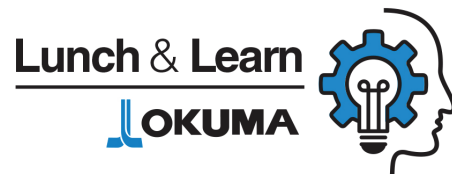

BUILD CORP 
DIRECT

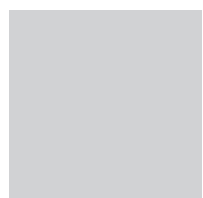

SPECIALTY

Document folders

Packaging

Promotional items



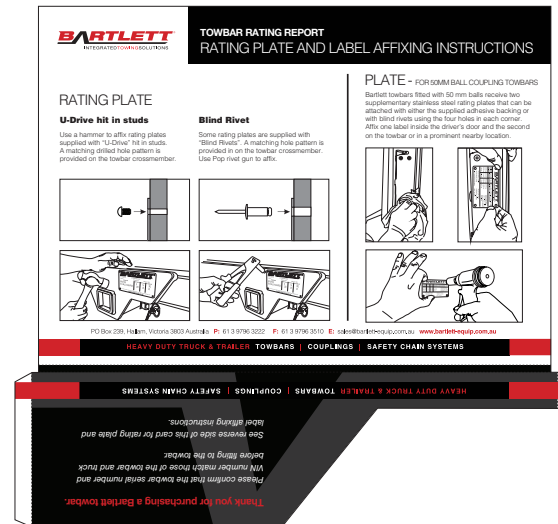
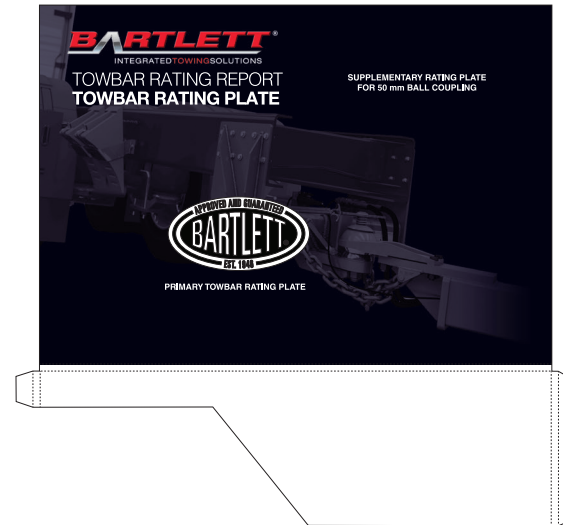
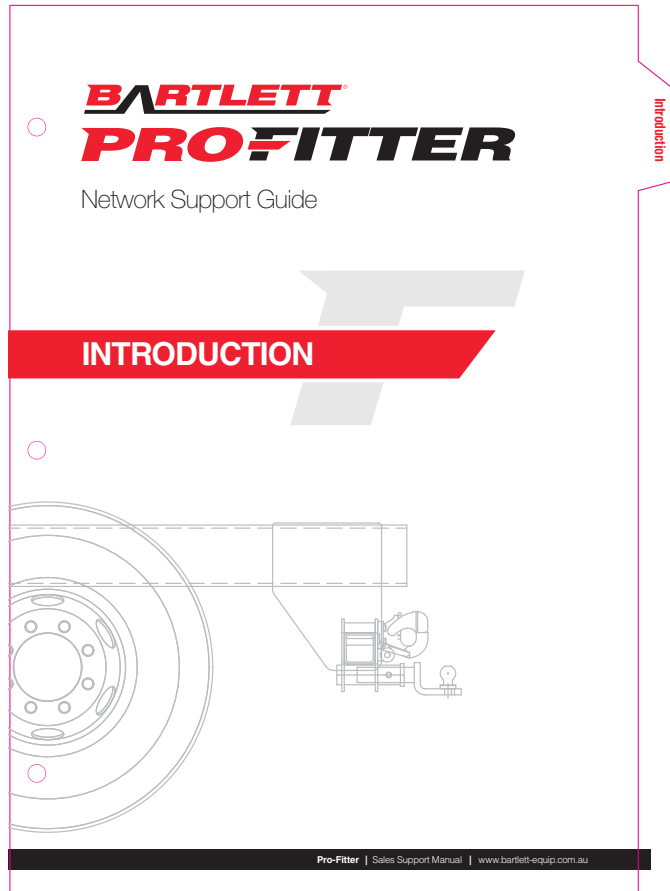

Typographics Design

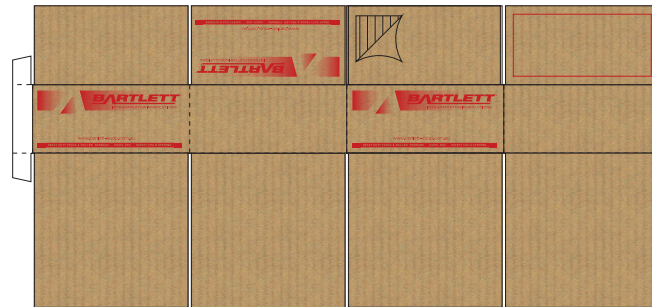
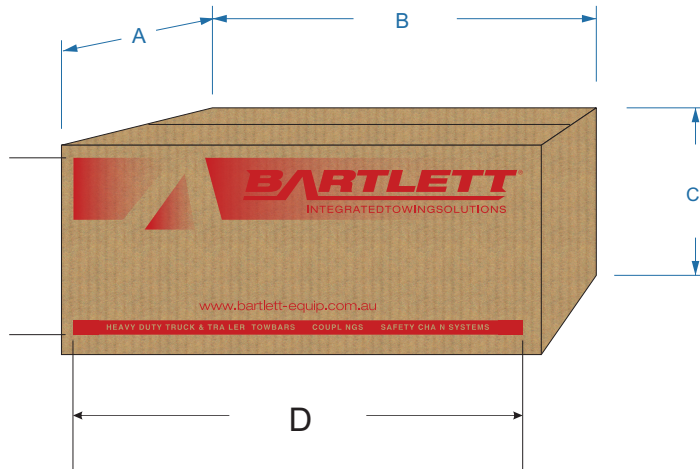



SPOT PMS

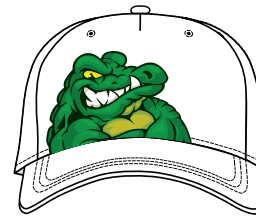

CMYK

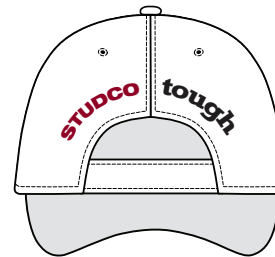

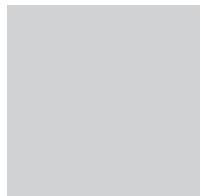

LARGE FORMAT

Exhibition displays

Large format posters

Rollup banners

Vehicle graphics

Environmental signage



**CNC SYNCHRONISED
BENDING THAT WON'T
BREAK THE BANK.
NOW THAT'S
APPLIED THINKING.**



- Delem DA-66T CNC controller
- 7 axis CNC controlled
- Synchronised, independent rams for precision delivery of the bending force across the entire bed
- Premium Roller tooling
- Lazersafe guarding for maximum operator safety
- Yawei is one of Australia's favourite CNC pressbrakes with over 200 machine sold across the country



To find out more:
Call: 03 9706 8066
Email: sales@appliedmachinery.com.au
Visit: www.appliedmachinery.com.au

Connect with us socially

LEADERS IN INNOVATIVE BUILDING PRODUCTS

STEEL STUD SYSTEMS
CONCEALED CEILING SYSTEMS
ARCHITECTURAL FINISHING SYSTEMS
SOUND ISOLATION SYSTEMS

www.studcosystems.com.au

We've got just the piece you've been looking for...

Asset Plant & Machinery is focused on meeting your requirements and supplying you with the best, professional services and products – guaranteed. We're **Your Partner In Machinery.**

- ✓ Extensive range of equipment to the metal working industries. New and Pre-owned.
- ✓ Extensive Warehouse showroom with machinery able to be tested.
- ✓ Installation training and support.

Unity Laser Profiling Machines
Gantry style or Cantilever style
Sheet Size from 3m x 15m Up To 4m x 12m

MVD Turret Punch
30Ton
1250 x 2500 mm Sheet
Bridge Type
AMADA Tooling Compatible

MVD CNC Hydraulic Press Brakes
Delem Control
80Ton – 800Ton

ASSET
Asset Plant & Machinery Pty Ltd
8 Capital Drive, Sandhurst VIC 3715
Tel: (03) 9791 1124
www.asset.com.au | info@asset.com.au
Tel: (03) 9791 1194

Typographics Design



Front Elevation

<p>1</p>  <p>Colorband Basalt</p>	<p>2</p>  <p>Color band Windspray</p>
<p>3</p>  <p>External Columns/Facade</p> <p>Alucobond Sparkling Black 888</p>	<p>4</p>  <p>Feature Fin</p> <p>Alucobond Red 201</p>

150mm RHS Steel Frame clad with Aluminium Composite Sheet with vinyl Burgundy background and cut-out letters mounted to the face.

3200 mm

2700 mm

160 mm

- ← White Composite
- ← Vinyl Background
- ← 20mm Cut-out Letters
- ← 10mm Cut-out Letters
- ← 10mm Cut-out Letters
- ← Linished Silver Composite

STUDCO
BUILDING SYSTEMS

130 - 140 Merrindale Drive



800 mm

800 mm

DOOR
2

600 mm

1800 mm

STUDCO
BUILDING SYSTEMS

GATE 1

- Reception
- Visitors Carpark

100 mm

60 mm